

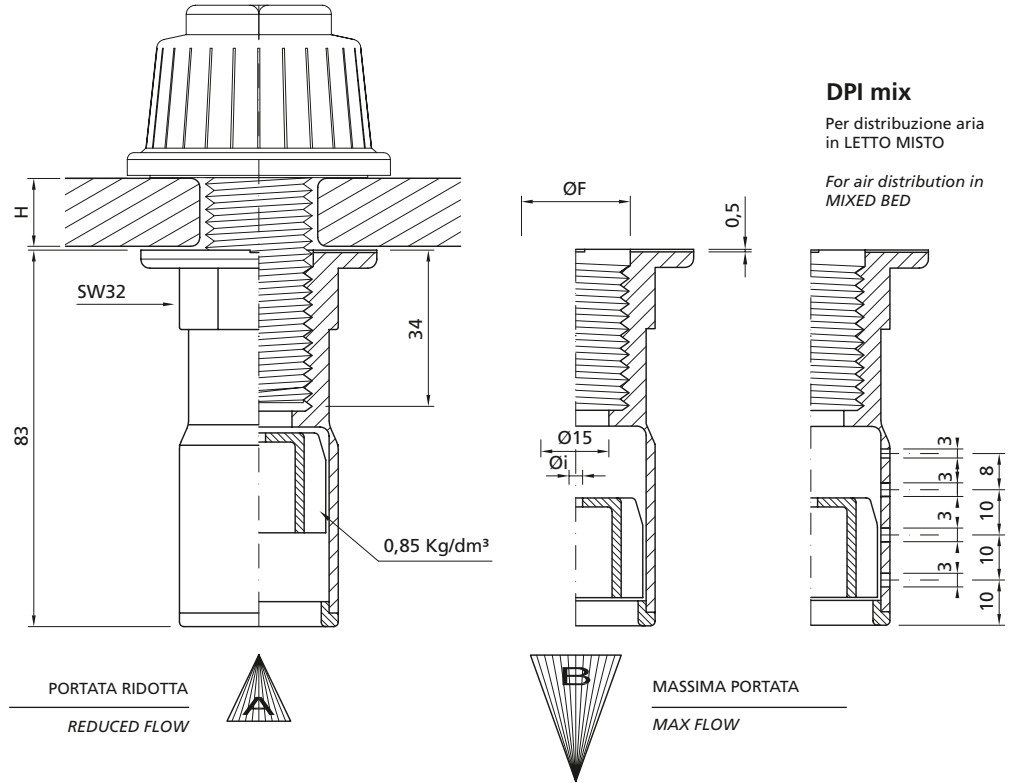

- Adatto per distribuire uniformemente la soluzione rigenerante delle resine, il cui flusso è inferiore e di direzione opposta a quello di esercizio.
- Suitable to uniformly distribute the regenerating solution of the resins, whose flow is lower and in opposite direction compared to operating flow.



Tipo Type	Colore Colour	Øi Diametro foro otturatore Shutter hole diameter mm	ØF Filetto Thread
DPI DPI mix	Bianco - White	1	M20x1,5 M20x2,5 1/2"G 3/4"G 15/16"W
	Grigio - Grey	2	
	Verde - Green	3	
	Blu - Blue	4	
	Arancio - Orange	5	
	Marrone - Brown	6	
	Giallo - Yellow	7	
	Nero - Black	8	
	Rosso - Red	1,5 - 2,5 - 3,5 - 4,5 - 5,5 - 6,5 - 7,5 - 8,5	

Come ordinare How to order	Esempio Example	
Valvola valve	DPI	DPI mix
ØF - Filetto Thread	15/16"W	3/4"G
Øi - Diametro foro otturatore Shutter hole diameter	5	7
Materiale Material	PP	PVDF

Materiale/Material:	PP - PPFV - PVDF
---------------------	------------------

