

MP

MANICOTTI PER PIASTRA SLEEVES FOR PLATE



- Adatto per l'installazione su filtri con lato inferiore piastra portaugelli inaccessibile

- Suitable for filters where access to the underside of the nozzle plate is not possible

MP

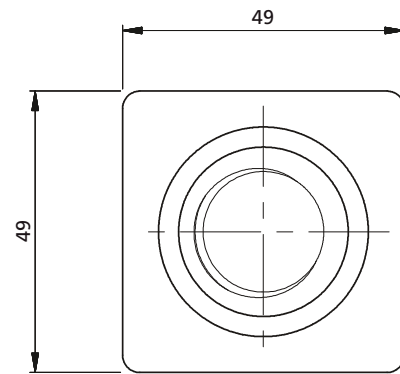
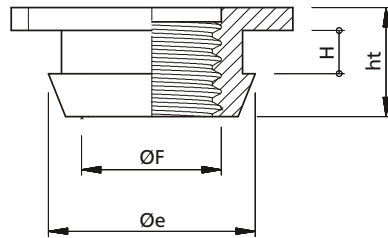

Vista dal basso MP
Bottom view MP

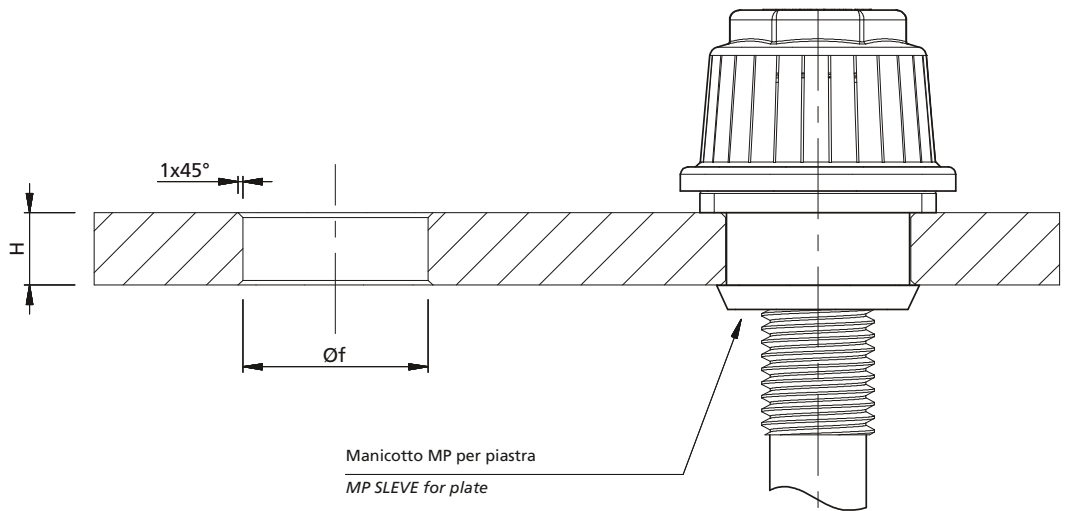

Tipo Type	H Spessore piastra Plate thickness mm	ht Altezza manicotto Sleeve height mm	Øf Diametro foro per installazione Mounting hole diameter mm	ØF Filetto Thread	Øe mm
MP03	3	19	Ø 31,5 ÷ 32,0	15/16"W	36
MP05	5	19	Ø 31,5 ÷ 32,0	15/16"W	36
			Ø 37,0 ÷ 37,5	1.1/4"W	40
MP7,5	7 ÷ 8	19	Ø 31,5 ÷ 32,0	15/16"W	36
			Ø 37,0 ÷ 37,5	1.1/4"W	40
MP10	10	22	Ø 31,5 ÷ 32,0	15/16"W	36
			Ø 37,0 ÷ 37,5	1.1/4"W	40
MP15	15	26	Ø 31,5 ÷ 32,0	15/16"W	36
			Ø 37,0 ÷ 37,5	1.1/4"W	40
MP25	25	36	Ø 31,5 ÷ 32,0	15/16"W	36

Come ordinare How to order	Manicotto Sleeve	Ø F - Filetto Thread	Materiale Material
Esempio / Example	MP10	15/16"W	PVC

Materiale/Material:	PVC compound 60 Sh.A (max. temp. 40°C)
	PP / EPDM 65 Sh.A (max. temp. 95°C)