

# UN - UD CF - PD - PDT

## TAPPI DI PROTEZIONE E FISSAGGIO - ACCESSORI PER MANICOTTI PROTECTION AND FIXING CAPS - SLEEVE'S ACCESSORIES

UN

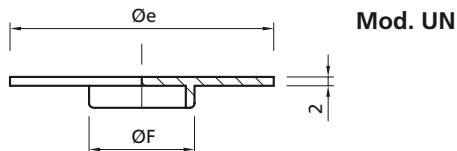

Tipo Type	Øe mm	ØF mm	Filetto manicotto Sleeve thread
UN	60, 70	26	15/16"W-1"W-M24-7/8"W-1/2"G
	60, 70	32	3/4"G - BSP - 1.1/4"W

Come ordinare How to order	Esempio / Example
Tappo / Cap	UN
Øe	60
ØF	26
Materiale / Material	PP

Materiale/Material: Polipropilene / Polypropylene

UD



- UN - UD: Utilizzati per proteggere il filetto e l'interno del manicotto durante il getto di cemento.

- UN - UD: used to protect the thread and the internal of the G sleeve during concrete casting

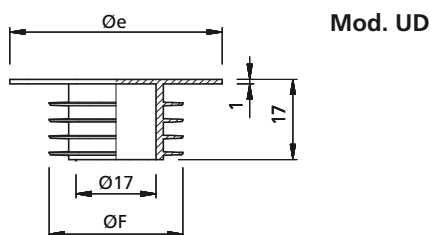

Tipo Type	Øe mm	ØF mm	Manicotto Sleeve
UD	45	28	G - GE

Materiale/Material: Polipropilene / Polypropylene

CF



PD - PDT



- CF - PD: Utilizzati per fissare il manicotto G sullo stampo durante il getto di cemento.

- CF - PD: used to fix the G sleeve during concrete casting

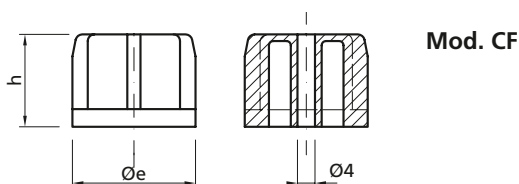

Adatto per tutti i tipi di manicotto G  
Suitable for all types of mod.G sleeves

Tipo Type	Øe mm	h mm	Manicotto Sleeve
CF	28,5	21	G - GE

Materiale/Material: Polipropilene / Polypropylene

Mod. PD - PDT

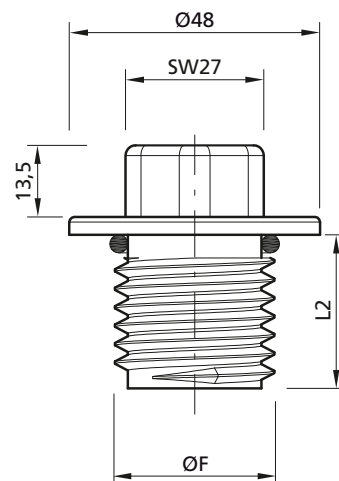

Tipo Type	ØF Filetto Manicotto Sleeve Thread	L2	O-Ring NBR
PD PDT	15/16"W	25, 35, 55	4075
	1"W	25, 35, 55	4075
	1.1/4"W	30, 55*	4100
	M24	35, 55	4075
	1/2"G	25, 35, 55	4075
	3/4"G	25, 35, 55	4075

PD - Fornito senza O-Ring è utilizzato per fissare il manicotto G durante il getto di cemento armato.

PD - Supplied without O-Ring, is used to fix G sleeve during concrete casting

Come ordinare How to order	Esempio / Example
Tappo / Cap	PD
ØF	15/16"W
L2	35
Materiale / Material	PP

PDT - Utilizzati per eseguire Test in Pressione su sistemi drenanti di filtri a gravità  
- Forniti completi di O-Ring, preassemblati e pronti per l'installazione  
- Il Testati a pressione di 10bar.

PDT - Used to perform Pressure Test on drain systems of gravity filters  
- Supplied complete with O-Ring, pre-assembled ready to be installed  
- Tested al pressure of 10 bar.

Come ordinare How to order	Esempio / Example
Tappo / Cap	PDT
ØF	15/16"W
L2	35
Materiale / Material	PP

\* Per Prova in Pressione con manicotto 11/4"W utilizzare PDT 30  
To perform Pressure Test with 11/4"W Sleeve use PDT 30